

## Product Specifications

### Includes:

- (1) 16 space rack
- (3) 2U space shelves
- (3) 2U space vented blanks
- (3) cable lacing bars

**Weight capacity:** RSW supports up to 150 lbs (68 kg) 2U shelf supports up to 50 lbs (22.7 kg)

**Mounting:** Double-stud

**Warranty:** 5 years

**Color:** Black

## Product Benefits

- Ships assembled
- Standard 19" rack enclosure works with all standard 19" rack accessories
- Integrated cable management channels for routing up to 3" bundles
- Adjustable shelves accommodate most components
- Vented for component cooling
- Shelf clamps secure components
- Left- or right-hinged door opens for serviceability
- Removable stainless steel handles
- Includes Grade 5 mounting hardware
- Additional accessories available



The RSW can swing open to the left or right, so you can choose what's best for your customer's specific needs



## Viking Series



RSF



RSF.5



RSW



Dedicated to being a one-stop shop for professional products, OmniMount remains on the cutting edge of product innovation. That's why we're the natural choice for any professional, industrial or commercial application. The Viking Series is a line of professional grade rack systems and accessories for managing components and giving an organized, polished look to any A/V installation. The RSW is a heavy duty wall rack system that's both cost-effective and fully assembled – perfect for applications where wall mounting components is preferred.



Dedicated to being a one-stop-shop for professional products, OmniMount remains on the cutting edge of product innovation. That's why we're the natural choice for any professional, industrial or commercial application. The Viking Series is a line of professional grade rack systems and accessories for managing components and giving an organized, polished look to any A/V installation. The RSW is a heavy duty wall rack system that's both cost-effective and fully assembled – perfect for applications where wall mounting components is preferred.

## Product Specifications

### Includes:

- (1) 16 space rack
- (3) 2U space shelves
- (3) 2U space vented blanks
- (3) cable lacing bars

**Weight capacity:** RSW supports up to 150 lbs (68 kg) 2U shelf supports up to 50 lbs (22.7 kg)

**Mounting:** Double-stud

**Warranty:** 5 years

**Color:** Black

## Product Benefits

- Ships assembled
- Standard 19" rack enclosure works with all standard 19" rack accessories
- Integrated cable management channels for routing up to 3" bundles
- Adjustable shelves accommodate most components
- Vented for component cooling
- Shelf clamps secure components
- Left- or right-hinged door opens for serviceability
- Removable stainless steel handles
- Includes Grade 5 mounting hardware
- Additional accessories available



	Stock Code	Packaging UPC	MC UPC
Americas	1003710-1	728901019814	NA
International	NA	NA	NA

	Dimensions WxDxH inches (mm)	Wt lbs (kg)
Product Box	NA	NA
Master Carton	NA	NA

Box Contents	Qty
Complete unit	1
2U shelf	3
2U vented blank	3
Complete hardware kit	1
Instruction manual	1

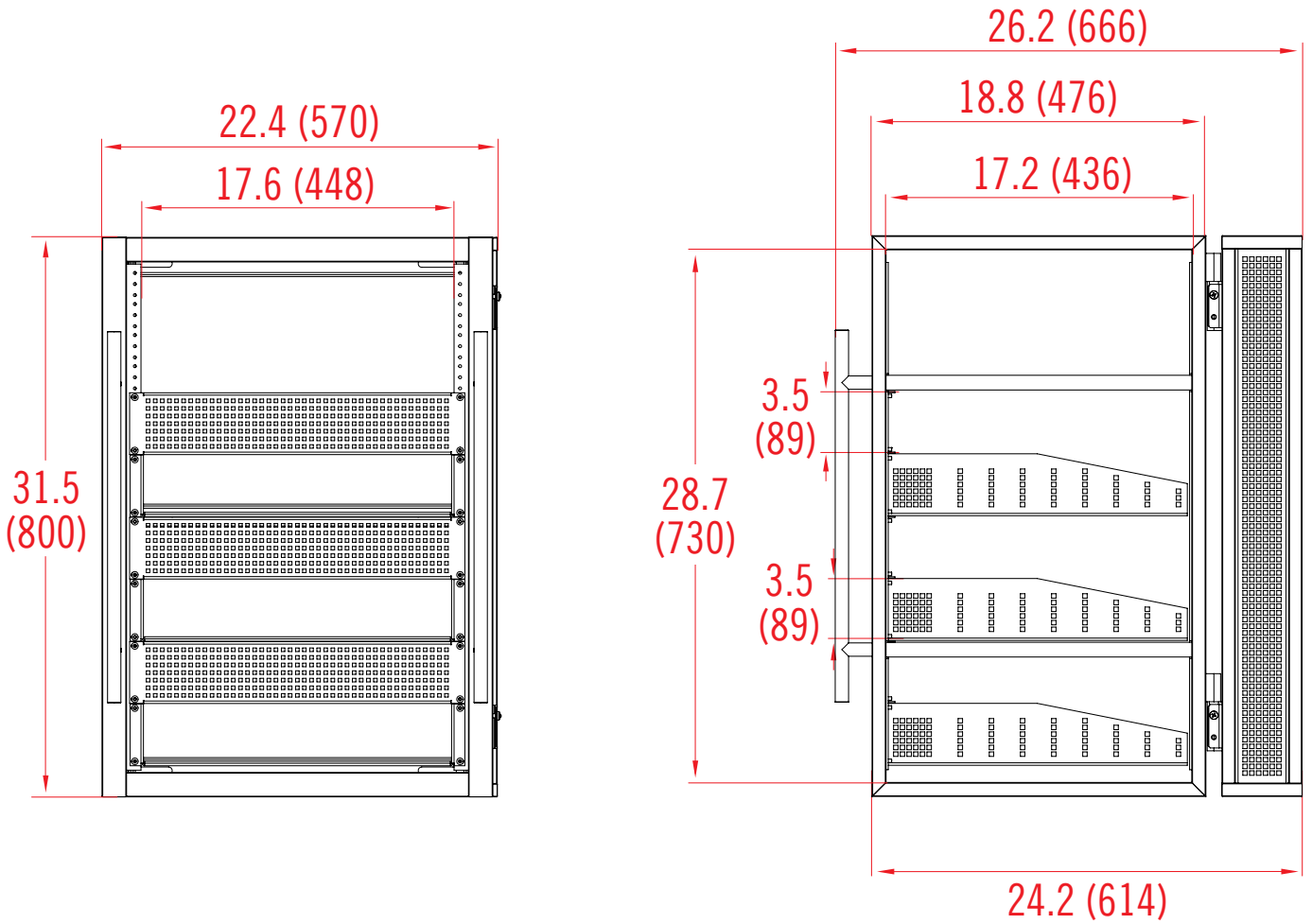

inches (mm)