

RSF.5 product information sheet

Product Specifications

Includes:

- (1) 16 space rack
- (3) 2U space shelves
- (3) 2U space vented blanks
- (3) cable lacing bars

Weight capacity:

- RSF.5 supports up to 500 lbs (226.8 kg)
- 2U shelf supports up to 50 lbs (22.7 kg)

Color: Black

Product Benefits

- Ships assembled
- Standard 19" rack enclosure works with all standard 19" rack accessories
- Caster base provides easy placement inside closets or against walls
- Integrated cable management channels for routing up to 3" bundles
- Adjustable shelves accommodate most components
- Vented for component cooling
- Shelf clamps secure components
- Large rubber wheels have integrated wheel lock
- Removable stainless steel handles
- Includes complete Grade 5 hardware kit
- Additional accessories available



The RSF.5 is the first fully assembled heavy duty floor half-rack system in its class.



Viking Series



RSF



RSF.5



RSVS-5U



RSVS-2U

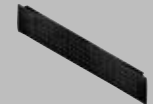

RSVB



RSFSP



Dedicated to being a one-stop-shop for professional products, OmniMount remains on the cutting edge of product innovation. That's why we're the natural choice for any professional, industrial or commercial application. The Viking Series is a line of professional grade rack systems and accessories for managing components and giving an organized, polished look to any A/V installation. The RSF.5 is a heavy duty floor half-rack system that's both cost-effective and fully assembled – perfect for applications where a full-size rack isn't needed.



RSF.5 technical data sheet



Dedicated to being a one-stop-shop for professional products, OmniMount remains on the cutting edge of product innovation. That's why we're the natural choice for any professional, industrial or commercial application. The Viking Series is a line of professional grade rack systems and accessories for managing components and giving an organized, polished look to any A/V installation. The RSF.5 is a heavy duty floor half-rack system that's both cost-effective and fully assembled – perfect for applications where a full-size rack isn't needed.

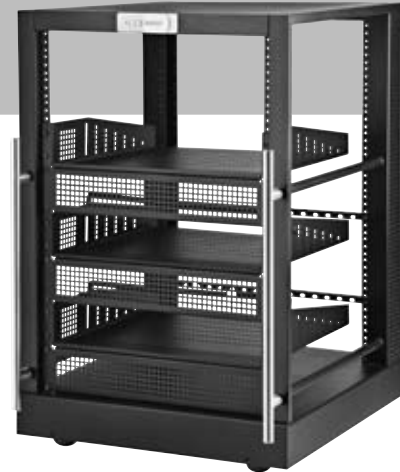

Product Specifications

Includes:

- (1) 16 space rack
- (3) 2U space shelves
- (3) 2U space vented blanks
- (3) cable lacing bars

Weight capacity:

- RSF.5 supports up to 500 lbs (226.8 kg)
- 2U shelf supports up to 50 lbs (22.7 kg)

Color: Black

Product Benefits

- Ships assembled
- Standard 19" rack enclosure works with all standard 19" rack accessories
- Caster base provides easy placement inside closets or against walls
- Integrated cable management channels for routing up to 3" bundles
- Adjustable shelves accommodate most components
- Vented for component cooling
- Shelf clamps secure components
- Large rubber wheels have integrated wheel lock
- Removable stainless steel handles
- Includes complete Grade 5 hardware kit
- Additional accessories available

	Stock Code	Packaging UPC	MC UPC
Americas	1004372-1	728901023019	NA
International	NA	NA	NA

	Dimensions WxDxH inches (mm)	Wt lbs (kg)
Product Box	25.8 x 27.6 x 36.4 (655x700x924)	TBD
Master Carton	NA	NA

Box Contents	Qty
16 space rack	1
2U shelf	3
2U vented blank	3
Handle	2
Cable lacing bar	3
Complete hardware kit	1
Instruction manual	1

RSF.5 line drawing

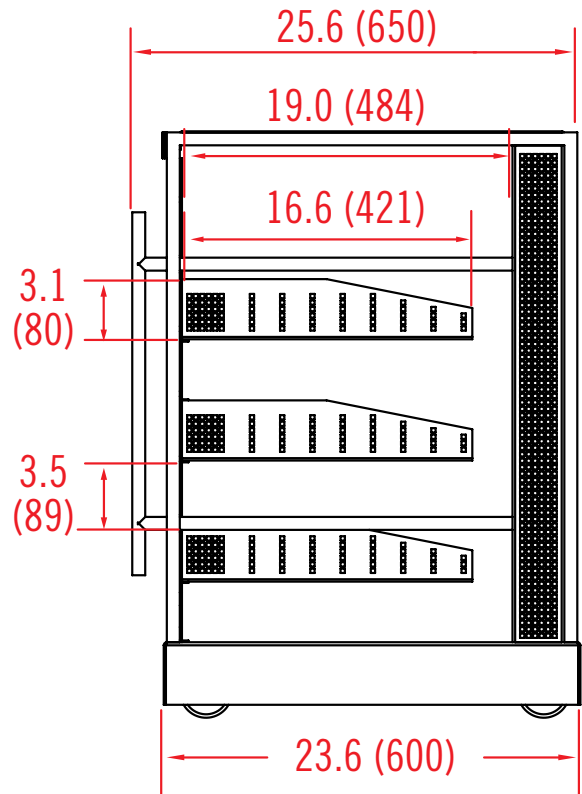
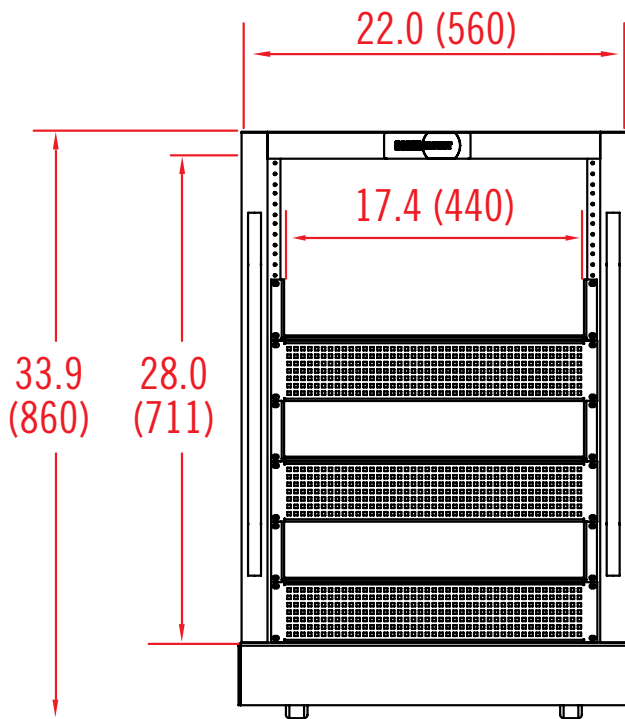

inches (mm)