

63FB-F product information sheet

Product Specifications

Fits most: 42" to 63" flat panels

Supports up to: 200 lbs (90.7 kg)

Mounting profile: 2.8" (72mm)

Universal & VESA compliant: 75x75, 100x100, 100x200, 200x200, 200x300, 300x400, 400x400, 400x600, 400x800

Mounting: Double- or Triple-stud

Color: Black

Product Benefits

- Universal rails for greater panel compatibility
- Low profile design
- Sliding lateral on-wall adjustments
- Open architecture for easy trim out
- Lift n' Lock™ for quick installation
- Locking system for added safety
- Anti-theft security feature
- Includes complete Grade 5 hardware kit



Keeping ease of installation in mind, the 63FB-F was designed to be installed in a few simple steps.

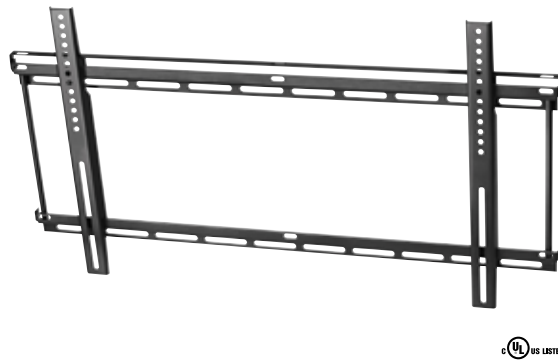

Series



37FB-T



37FB-F



54FB-T



54FB-F



63FB-T

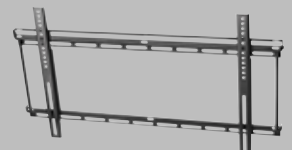

63FB-F



Dedicated to being a one-stop-shop for professional products, OmniMount remains on the cutting edge of product innovation. That's why we're the natural choice for any professional, industrial or commercial application. The Fastback Series offers both fixed and tilt universal mounting solutions that are designed for quick and easy installs. The 63FB-F is the ideal mount for budget-conscious customers or high-volume jobs requiring a dependable large/extra large fixed mount.



63FB-F technical data sheet



Dedicated to being a one-stop-shop for professional products, OmniMount remains on the cutting edge of product innovation. That's why we're the natural choice for any professional, industrial or commercial application. The Fastback Series offers both fixed and tilt universal mounting solutions that are designed for quick and easy installs. The 63FB-F is the ideal mount for budget-conscious customers or high-volume jobs requiring a dependable large/extra large fixed mount.

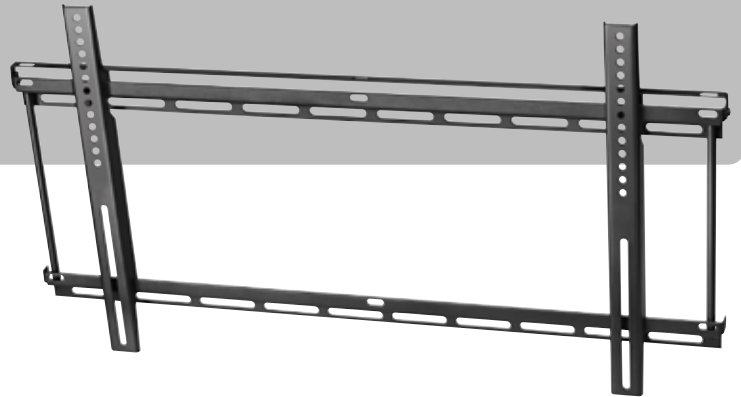

Product Specifications

Fits most: 42" to 63" flat panels

Supports up to: 200 lbs (90.7 kg)

Mounting profile: 2.8" (72mm)

Universal & VESA Compliant: 75x75, 100x100, 100x200, 200x200, 200x300, 300x400, 400x400, 400x600, 400x800

Mounting: Double- or Triple-stud

Color: Black

Product Benefits

- Universal rails for greater panel compatibility
- Low profile design
- Sliding lateral on-wall adjustment
- Open architecture for easy trim out
- Lift n' Lock™ for quick installation
- Locking system for added safety
- Anti-theft security feature
- Includes complete Grade 5 hardware kit

	Stock Code	Packaging UPC	MC UPC
Americas	1004082-1	728901021695	NA
International	NA	NA	NA

	Dimensions WxDxH Inches (mm)	Wt lbs (kg)
Product Box	43.5 x 17.4 x 3.2 (1105x443x60)	22.1 (10)
Master Carton	NA	NA

Box Contents	Qty
Wall plate	1
Vertical rail	2
Locking bar	1
Complete mount installation hardware kit	1
Complete panel attachment hardware kit	1
Instruction manual	1
Flat panel compatibility chart	1

63FB-F line drawing

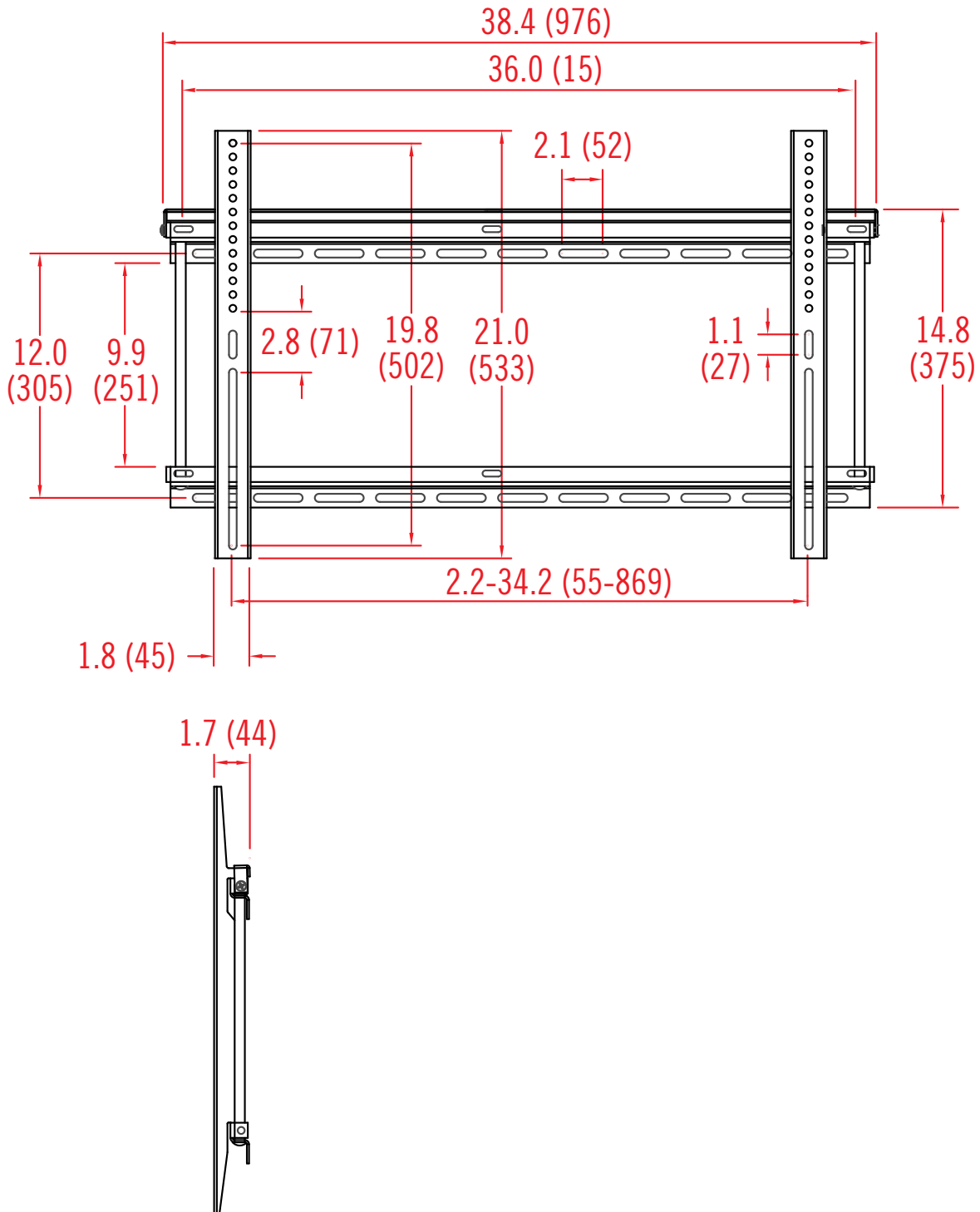

inches (mm)

Architects Specifications

The flat panel wall mount shall be an OmniMount model 63FB-F and shall be located where indicated on the plans. It shall be constructed of sheet metal. Assembly and installation shall be done according to instructions provided by the manufacturer.